

Piston Ring-to-Groove Clearance

Special Tool(s)

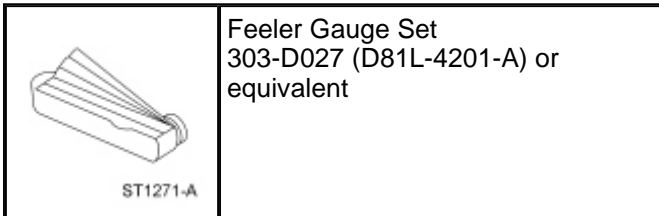

NOTE: Refer to the appropriate Section 303-01 for the specification.

1. Inspect the piston for ring land damage or accelerated wear.

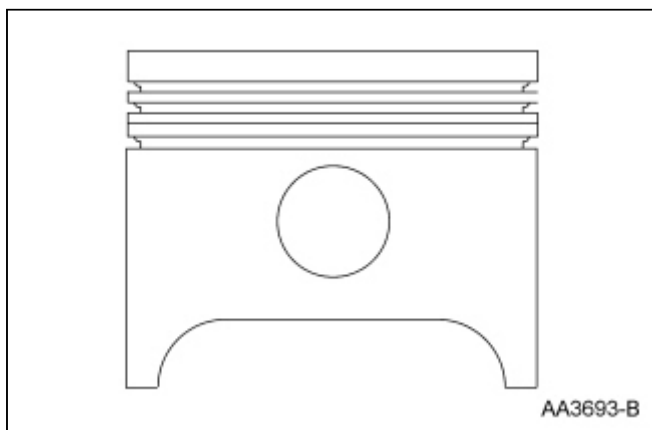

2. Using the Feeler Gauge Set, measure the piston ring-to-groove clearance.

